

FUEL STEP AND HANDLE INSTALLATION

EFFECTIVITY

<u>Model</u>	<u>Year</u>	<u>Serial Numbers</u>
172K	1969	17257162 thru 17258486
172K	1970	17258487 thru 17259223
172L	1971	17259224 thru 17259903
172L	1972	17259904 thru 17260758
172M	1973	17260759 thru 17261444
172M	1973	17261446 thru 17261577
172M	1973	17261579 thru 17261898
172M		17256493
172M	1974	17261899 thru 17263458
172M	1975	17263459 thru 17265684
172M	1976	17265685 thru 17267584
172N	1977	17267585 thru 17269309
172N		17261445
172N	1978	17269310 thru 17270049
172N	1978	17270051 thru 17271034
172N		17261578
172N	1979	17271035 thru 17272884
172N	1980	17272885 thru 17274009
172N		17270050
172P	1981	17274010 thru 17275034
172P	1982	17275035 thru 17275759
172P	1983	17275760 thru 17276079
172P	1984	17276080 thru 17276259
172P	1985	17276260 thru 17276516
172P	1986	17276517 thru 17276654
172Q	1983	17275869
172Q	1983	17275927 thru 17275934

April 21, 2006

Original Issue: December 5, 1983

Page 1 of 13

To obtain satisfactory results, procedures specified in this publication must be accomplished in accordance with accepted methods and prevailing government regulations. Cessna Aircraft Company cannot be responsible for the quality of work performed in accomplishing the requirements of this publication.

ACCESSORY KIT

AK172-168J

172Q	1983	17275952, 17275959, 17275960
172Q	1983	17275962, 17275964, 17275965
172Q	1983	17275967, 17275968, 17275969
172Q	1983	17275971, 17275992, 17275999
172Q	1983	17276002, 17276005, 17276029
172Q	1983	17276032, 17276042, 17276045
172Q	1983	17276051, 17276052, 17276054
172Q	1984	17276101, 17276109, 17276140
172Q	1984	17276147, 17276188, 17276211
R172K	1977	R1722000 thru R1722724
R172K	1978	R1722725 thru R1722929
R172K	1979	R1722930 thru R1723199
R172K		680
R172K	1980	R1723200 thru R1723399
R172K	1981	R1723400 thru R1723454
F172H	1969	F172-0560 thru F172-0654
F172H	1970	F17200655 thru F17200754
F172K	1971	F17200755 thru F17200804
F172L	1972	F17200805 thru F17200904
F172M	1973	F17200905 thru F17201034
F172M	1974	F17201035 thru F17201234
F172M	1975	F17201235 thru F17201384
F172M	1976	F17201385 thru F17201514
F172N	1977	F17201515 thru F17201639
F172N	1978	F17201640 thru F17201749
F172N	1979	F17201750 thru F17201909
F172N	1980	F17201910 thru F17202039
F172P	1981	F17202040 thru F17202134
F172P	1982	F17202135 thru F17202194
F172P	1983	F17202195 thru F17202216
F172P	1984	F17202217 thru F17202233
F172P	1985	F17202234 thru F17202238
F172P	1986	F17202239 thru F17202254
FR172F	1969	FR17200061 thru FR17200145
FR172G	1970	FR17200146 thru FR17200225
FR172H	1971	FR17200226 thru FR17200275
FR172H	1972	FR17200276 thru FR17200350

ACCESSORY KIT

AK172-168J

FR172J	1973	FR17200351 thru FR17200440
FR172J	1974	FR17200441 thru FR17200530
FR172J	1975	FR17200531 thru FR17200559
FR172J	1976	FR17200560 thru FR17200590
FR172K	1977	FR17200591 thru FR17200620
FR172K	1978	FR17200621 thru FR17200630
FR172K	1979	FR17200631 thru FR17200655
FR172K	1980	FR17200656 thru FR17200665
FR172K	1981	FR17200666 thru FR17200675

DESCRIPTION

To install refueling handles and steps on the airplane.

APPROVAL

FAA approval has been obtained on technical data in this publication that affects airplane type design.

REFERENCE

CHANGE IN WEIGHT AND BALANCE

MODEL	172, F172, R172, FR172, 172Q
WEIGHT INCREASE	2.016 pounds
ARM	17.8 inches
RESULTANT MOMENT	35.88 inch-pounds
MOMENT/1000	0.036

MATERIAL INFORMATION

Order the following kit to install the handle and strut step.

NEW P/N	QUANTITY	DESCRIPTION	OLD P/N	DISPOSITION
AK172-168J	1	Kit , consisting of the following parts:		
AN3-4A	4	Bolt	None	None
AN3-5A	8	Bolt		
AN3-6A	6	Bolt		
AN970-3	2	Washer		
NAS1149F0432P	4	Washer	None	None
MS20470AD4-4	12	Rivet	None	None
MS20470AD4-4A5	28	Rivet	None	None

ACCESSORY KIT

AK172-168J

MS20470AD4-5	12	Rivet	None	None
MS20470AD4-5A5	12	Rivet	None	None
MS20470AD4-6	8	Rivet	MS20470AD4	Discard
MS20470AD5-7	4	Rivet	None	None
MS21042L4	4	Nut	None	None
MS21044N3	18	Nut		
NAS1149D0332H	16	Washer		
S1450-4H12-050	4	Washer	None	None
S2906-4-2	8	Rivet	None	None
S2906-4-3	2	Rivet	None	None
0500276-1	1	Step - Left Strut	None	None
0500276-2	1	Step - Right Strut	None	None
0513429-1	1	Doubler - Left	None	None
0513429-2	1	Doubler - Right	None	None
0513582-5	1	Reinforcement - Left		
0513582-6	1	Reinforcement - Right		
0513582-11	2	Doubler		
1613224-2	2	Handle	None	None
	1	Instructions	None	None

In addition to the AK172-168J kit, airplanes 17272885 thru 17276654, F17201910 thru F17202254, R1723200 thru R1723454 and FR17200656 thru FR17200675, order the following parts to install the 0513526-1 (left) and 0513526-2 (right) Fuel Step.

NEW P/N	QUANTITY	DESCRIPTION	OLD P/N	DISPOSITION
0513526-1	1	Step - Left	None	None
0513526-2	1	Step - Right	None	None

In addition to the AK172-168J kit, airplanes 17257162 thru 17272884, F17200560 thru F17201909, R1722000 thru R1723199, 680 and FR17200061 thru FR17200655, order the following kit to install the 0713194-3 Fuel Step.

NEW P/N	QUANTITY	DESCRIPTION	OLD P/N	DISPOSITION
0713194-3	2	Step	None	

ACCESSORY KIT

AK172-168J

The following material, or equivalent, is necessary.

NUMBER	NAME	MANUFACTURER	USE
CMNP021CLASSB2	Sealant (Semkit, 6 oz.)	Cessna Aircraft Company Cessna Parts Distribution 5800 East Pawnee PO Box 1521 Wichita, KS 67218	To fay seal doubler and reinforcement.
Alodine 1132	Touch-N-Prep	Cessna Aircraft Company Cessna Parts Distribution 5800 East Pawnee PO Box 1521 Wichita, KS 67218	To apply to bare metal.
513 x 419910 x 942	Corrosion Resistant Primer	PRC-DeSoto International 5430 San Fernando Road Glendale, CA 91209	To apply to bare metal.

ACCOMPLISHMENT INSTRUCTIONS

1. Prepare the airplane for maintenance.
 - A. Make sure that all switches are in the OFF/NORM position.
 - B. Disconnect electrical power from the airplane.
 - (1) Disconnect the airplane battery.
 - (2) Disconnect external electrical power.
 - C. Attach maintenance warning tags to the battery and external power receptacle that have **"DO NOT CONNECT ELECTRICAL POWER - MAINTENANCE IN PROGRESS"** written on them.

NOTE: The installation of this kit consists of:

- A handle installed on the right and on the left forward cowl deck.
 - A step assembly installed on the right and on the left wing strut.
 - A step assembly installed on the right and on the left side of the fuselage.
2. Install the handles.
 - A. Remove the pilot and copilot seats as necessary.
 - B. Remove the left side instrument shock panel and the right side instruments as necessary to get access to the area where the 1613224-2 Handles are to be installed.
 - C. Remove the butt of the four rivets that interfere with the 0513429 Doublers (two on each side of the airplane's cowl deck) and make them flush with surface.
 - D. (Refer to Figure 1, Detail A.) Drill out five existing MS20470AD4 Rivets on each side of the forward cowl deck at locations shown.
 - E. Put a 0513429 Doubler on the underside of the left and the right forward cowl deck and align the pilot holes of each doubler with the holes where the rivets were removed.
 - F. Match drill five Number 30 (0.128-inch diameter) holes in the cowl deck and the 0513429 Doubler.
 - G. Hold the 0513429 Doublers in place with temporary metal fasteners, then back drill and ream the seven holes through the forward cowl deck to match the doublers.
 - H. Drill a 0.25 inch diameter hole through the cowl at each handle location predrilled in each doubler. Ream each handle hole to 0.257 inch diameter hole and deburr each hole as necessary.

ACCESSORY KIT

AK172-168J

- I. Deburr all holes and apply a thin coat of applicable CMNP021CLASSB2 Sealant to the mating surfaces of the cowl deck and the doublers.
 - J. Install the doublers with MS20470AD4-4A5 Rivets.
 - K. Install the two handles in the drilled holes on each side of the fuselage and attach each handles with S1450-4H12-050 Washers, NAS1149F0432P Washers, and with MS21042L4 Nuts.
3. (Refer to Figure 2, Detail A.) Install the wing strut steps.
- A. Put the 0500276 Step Assemblies on the wing struts approximately 25 inches from the fuselage attach points.
 - B. Attach the 0500276 Step Assemblies to the wing struts with AN3-4A Bolts, NAS1149D0332H Washers and MS21044N3 Nuts.
4. (Refer to Figure 3, View A-A.) Install the 0513526-1 (0513526-2) Fuel Step for the following serial numbers.

MODEL	SERIAL EFFECTIVITY
172	17272885 thru 17276654
F172	F17201910 thru F17202254
R172	R1723200 thru R1723454
FR172	FR17200656 thru FR17200675

NOTE: Airplanes with serial numbers not shown above, go to Step 5.

- A. Remove or relocate as necessary, the interior carpet, panels, and other parts that are in the area of the fuselage steps. Keep all interior parts removed.
- B. Put the 0513582-11 Doubler on the exterior side of the skin in the location shown.
- C. Remove the rivets that are installed through the floorboard and the forward door frame where the 0513582-11 Doubler will be installed.
- D. Put the 0513582-5 (left) (0513582-6 right) Reinforcement, on the internal side of the skin using the 0.31-inch dimension and with the lower edge of the reinforcement as close to the floorboard bend-radius as possible.
 - (1) Drill one Number 30 (0.128-inch diameter) hole, centered between where the most forward bolt hole will be located and the rivet on the floorboard flange.
 - (2) Use the hole location drilled in the step above and WL -17.76 to locate the 0513582-11 Doubler.
 - (3) Match drill all the current skin holes through the 0513582-11 Doubler and 0513582-5 (left) (0513582-6 right) Reinforcement.
- E. Use temporary fasteners to hold the 0513582-11 Doubler, and 0513582-5 (left) (0513582-6 right) Reinforcement together and in position.
- F. Match drill the pilot holes of the 0513582-11 Doubler and 0513582-5 (left) (0513582-6 right) Reinforcement with a Number 30 (0.128-inch diameter) drill.
- G. Drill one Number 30 (0.128-inch diameter) hole, centered between the hole drilled in Step 4C(1) and the rivet installed directly above.
- H. Trim the 0513582-11 Doubler per the 0.38-inch dimension.
- I. Drill one Number 30 (0.128-inch diameter) hole in the lower aft corner of the 0513582-11 Doubler as shown.
- J. Put the 0513526 Fuel Step in position on the 0513582-11 Doubler and match drill six Number 30 (0.128 inch diameter) holes.

ACCESSORY KIT

AK172-168J

- K. Drill the six holes in the 0513526 Fuel Step, 0513582-11 Doubler, the airplane skin, and the 0513582 Reinforcement, to Number 10 (0.193 inch diameter).

NOTE: Make sure to keep a minimum edge distance of one times diameter on the 0513526 Fuel Step.

- L. Measure and drill one Number 10 (0.193 inch diameter) hole 0.60 inch from the step forward edge and as close as possible to the step bend radius. Make sure the hole is not drilled too close to the step bend radius which will not let the AN3-5A Bolt head be installed flush.

- M. Deburr all the holes drilled in the airplane skin, the 0513582-5 (left) (0513582-6 right) Reinforcements, and the 0513582-11 Doubler.

- N. Apply CMNP021CLASSB2 Sealant to the faying surfaces of the 0513582-11 Doubler.

- O. Attach the 0513582-11 Doubler, and the 0513582-5 (left) (0513582-6 right) Reinforcements with temporary fasteners.

- P. Install one MS20470AD4-6 Rivet at the location shown.

- Q. Install remaining fasteners as shown.

NOTE: One size larger fastener is permitted. Make sure two times diameter edge distance is kept.

- R. Install one AN3-5A Bolt through the step, doubler, skin, and reinforcement, and attach it with a AN970-3 Washer and MS21044N3 Nut in the lower forward hole.

- S. Install two AN3-5A bolts, NAS1149D0332H Washers, and MS21044N3 Nuts through the aft end of the 0513526 Step and the 0513582-11 Doubler as shown.

- T. Install one AN3-5A bolt, NAS1149D332H Washer, and MS21044N3 Nut through the Step, Doubler, Skin, and Reinforcement in the upper forward hole.

- U. Install three AN3-6A Bolts, NAS1149D0332H Washers, and MS21044N3 Nuts through the 0513582-5 (left) (0513582-6 right) Reinforcement.

- V. Do Step 4 on the opposite side.

- W. Install the interior carpet, panels, and parts in the area of the fuselage step.

- X. Go to Step 6.

5. (Refer to Figure 4, View A-A.) Install the 0713194-3 Fuel Steps for the following serial numbers.

MODEL	SERIAL EFFECTIVITY
172	17257162 thru 17272884
F172	F17200560 thru F17201909
R172	R1722000 thru R1723199
	680
FR172	FR17200061 thru FR17200655

- A. Remove or relocate as necessary, the interior carpet, panels, and other parts that are in the area of the fuselage steps. Keep all interior parts removed.

- B. Remove the rivets that are installed through the floorboard and the forward door frame where the 0513582-11 Doubler will be installed.

- C. Locate the 0513582-11 Doubler on the exterior of the skin with the 0.25 and 0.31-inch minimum dimensions.

- D. Trim the 0513582-11 Doubler per the 0.38-inch dimension.

(1) Use the hole locations that are drilled in the skin to match drill through the 0513582-11 Doubler.

ACCESSORY KIT

AK172-168J

- E. Put the 0513582-5 (left) (0513582-6 right) Reinforcement on the interior of the skin at the 0.66-inch position and with the lower edge of the reinforcement as close to the floorboard inside bend-radius as possible as shown.
- (1) Make sure two times diameter edge distance is kept when you locate 0.66 inch hole locations.
- NOTE:** Once the 0.66-inch hole locations are established, it is permissible to have one and one half rivet edge distance between the fasteners and the step mounting holes where drilled.
- (2) Match drill all the current skin holes through the 0513582-11 Doubler and 0513582-5 (left) (0513582-6 right) Reinforcement.
- F. Use temporary fasteners to hold the 0513582-11 Doubler and 0513582 Reinforcement together in position.
- G. Match drill the pilot holes of the 0513582-11 Doubler and 0513582-5 (left) (0513582-6 right) Reinforcement with a Number 30 (0.128-inch diameter) drill.
- H. Measure 0.66-inch aft of the forward rivet removed along the floorboard flange, and make a mark for a new hole.
- I. Drill one Number 30 (0.128-inch diameter) hole at the hole location marked above.
- J. Drill one Number 30 (0.128-inch diameter) hole in the center at LOCATION B between the upper forward corner pilot hole (LOCATION A) drilled in the 0513582-11 Doubler and the forward rivet removed along the floorboard flange.
- K. Position the 0713194 Fuel Step on the 0513582-11 Doubler and match drill the six Number 30 (0.128 inch diameter) holes.
- L. Drill the six holes in the 0713194 Fuel Step, 0513582-11 Doubler, the airplane skin, and the 0513582 Reinforcement to Number 10 (0.193-inch diameter).
- NOTE:** Make sure to keep a minimum edge distance of one times diameter on the 0713194 Fuel Step.
- M. Mark and drill one Number 30 (0.128-inch diameter) hole at LOCATION C between the lower aft hole in the 0513582-11 Doubler and the lower aft hole in the 0713194 Fuel Step.
- N. Remove the 0713194 Fuel Step, 0513582-11 Doubler, and the 0513582 Reinforcement. Deburr the holes. Apply Alodine as necessary.
- O. Measure two times diameter edge distance from the aft edge of the 0513582-11 Doubler.
- (1) Remove any extra material beyond the two rivet edge distance as necessary.
- (2) Deburr all holes drilled.
- (3) Apply color chemical film treatment and corrosion resistant primer to bare metal edges.
- P. Apply CMNP021CLASSB2 Sealant to the faying surfaces of the 0513582-11 Doubler and 0513582-5 (left) (0513582-6 right) Reinforcement.
- Q. Attach the 0513582-11 Doubler, and the 0513582-5 (left) (0513582-6 right) Reinforcements in place with temporary fasteners.
- (1) Install one MS20470AD4-6 Rivet in the hole drilled in Step 5J.
- (2) Install the remaining fasteners as shown.
- NOTE:** One size larger fastener is permitted. Make sure two times diameter edge distance is kept.

ACCESSORY KIT

AK172-168J

- R. Install the 0713194-3 Fuel Step.
 - (1) Install three AN3-5A bolts, NAS1149D0332H Washers, and MS21044N3 Nuts through the 0713194 Fuel Step (two through the aft end of the 0513582-11 Doubler and one on the forward upper bolt hole) as shown.
 - (2) Install three AN3-6A bolts, NAS1149D0332H Washers, and MS21044N3 Nuts through the 0713194 Step, 0513582-11 Doubler, and 0513582-5 (left) (0513582-6 right) Reinforcements.
- S. Do Step 5 on the opposite side.
- T. Install the interior carpet, panels and parts in the area of the fuselage step.
- 6. Install the pilots and copilots seat and any upholstery and panels that were removed or relocated.
- 7. Paint the handle and steps to match the airplane.
- 8. Remove maintenance warning tags and reconnect the airplane battery. (Refer to the applicable Service Manual.)
- 9. Do a functional test of any equipment or systems disconnected or removed that have been connected and installed after the steps and handles have been installed.
- 10. Make an entry in the airplane logbook stating this service kit has been installed.

ACCESSORY KIT

AK172-168J

B2060

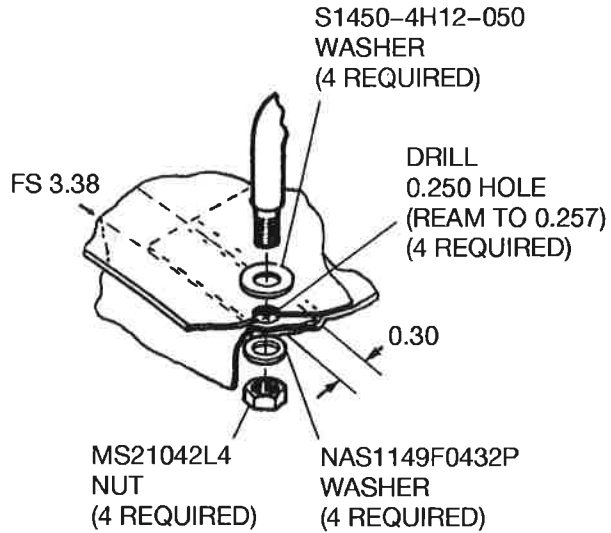
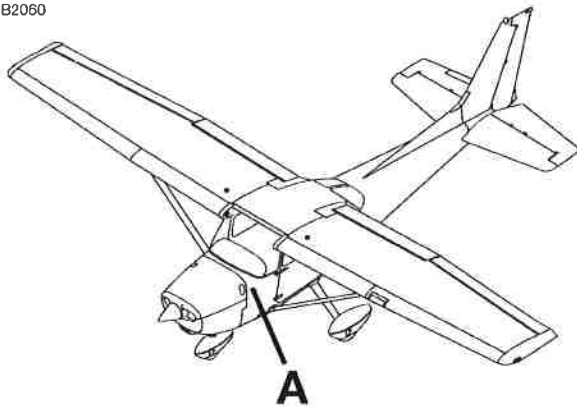

- NOTE 1:** ALL DIMENSIONS ARE IN INCHES.
- NOTE 2:** QUANTITIES SHOWN ARE FOR BOTH SIDES OF AIRPLANE.
- NOTE 3:** REMOVE BUTT OF RIVETS TO MAKE A FLUSH SURFACE.

DETAIL B

HANDLE INSTALLATION

NUMBER 30
(0.128-INCH
DIAMETER) HOLE
MS20470AD4-6
RIVETS
(3 REQUIRED)

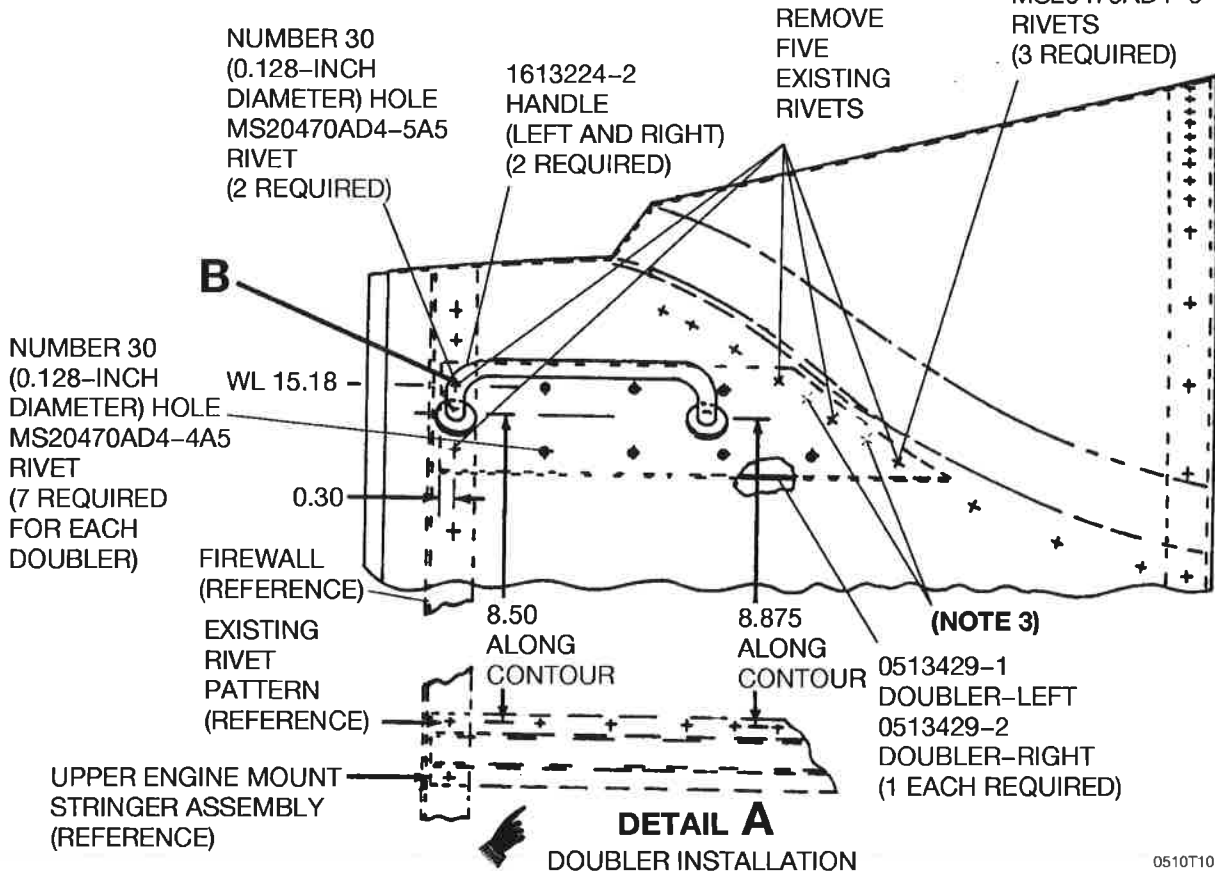

DETAIL A

DOUBLER INSTALLATION

Figure 1. Installation of Handle (Sheet 1)

0510T1007

ACCESSORY KIT

AK172-168J

B2071

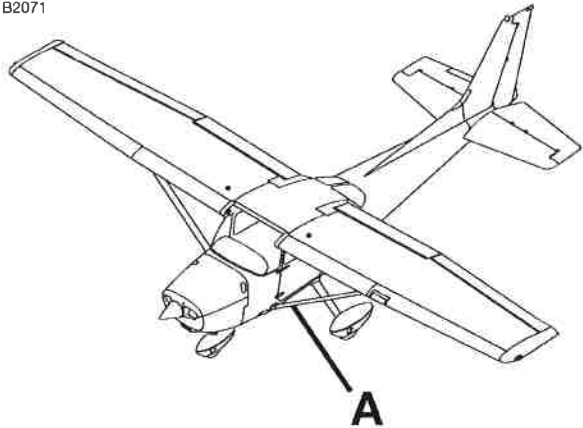

NOTE: QUANTITIES SHOWN ARE FOR BOTH SIDES OF AIRPLANE.

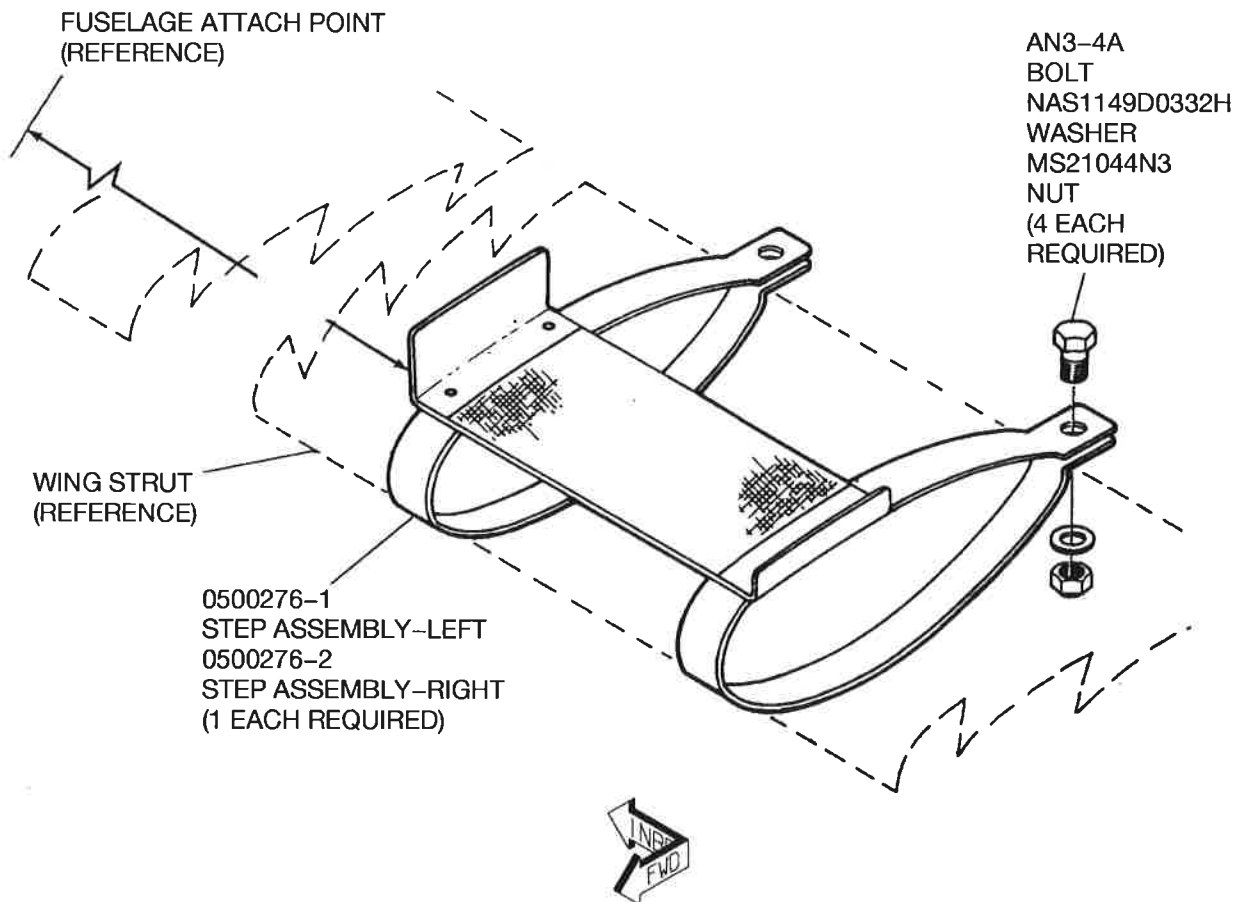

DETAIL A

WING STRUT STEP INSTALLATION
(LEFT SIDE SHOWN, RIGHT SIDE OPPOSITE)

0510T1007

Figure 2. Installation of the Strut Steps (Sheet 1)

ACCESSORY KIT

AK172-168J

B2080

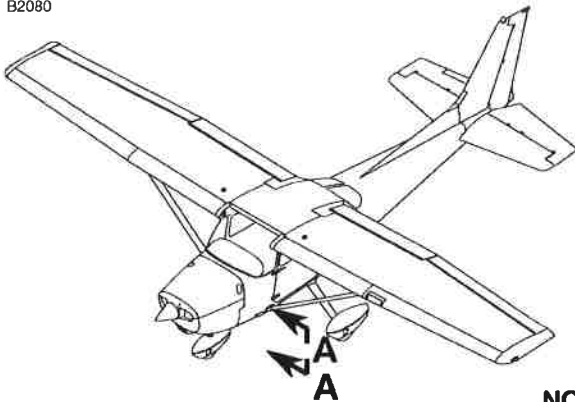

RIVET LEGEND	
	MS20470AD4-4
	MS20470AD4-5 (NOTE 2)
	MS20470AD4-6
	S2906-4-2
	S2906-4-3

NOTE 1: ALL DIMENSIONS SHOWN ARE IN INCHES.

NOTE 2: USE MS20426AD4-5 INSTEAD OF MS20470AD4-5 IF REQUIRED FOR CLEARANCE.

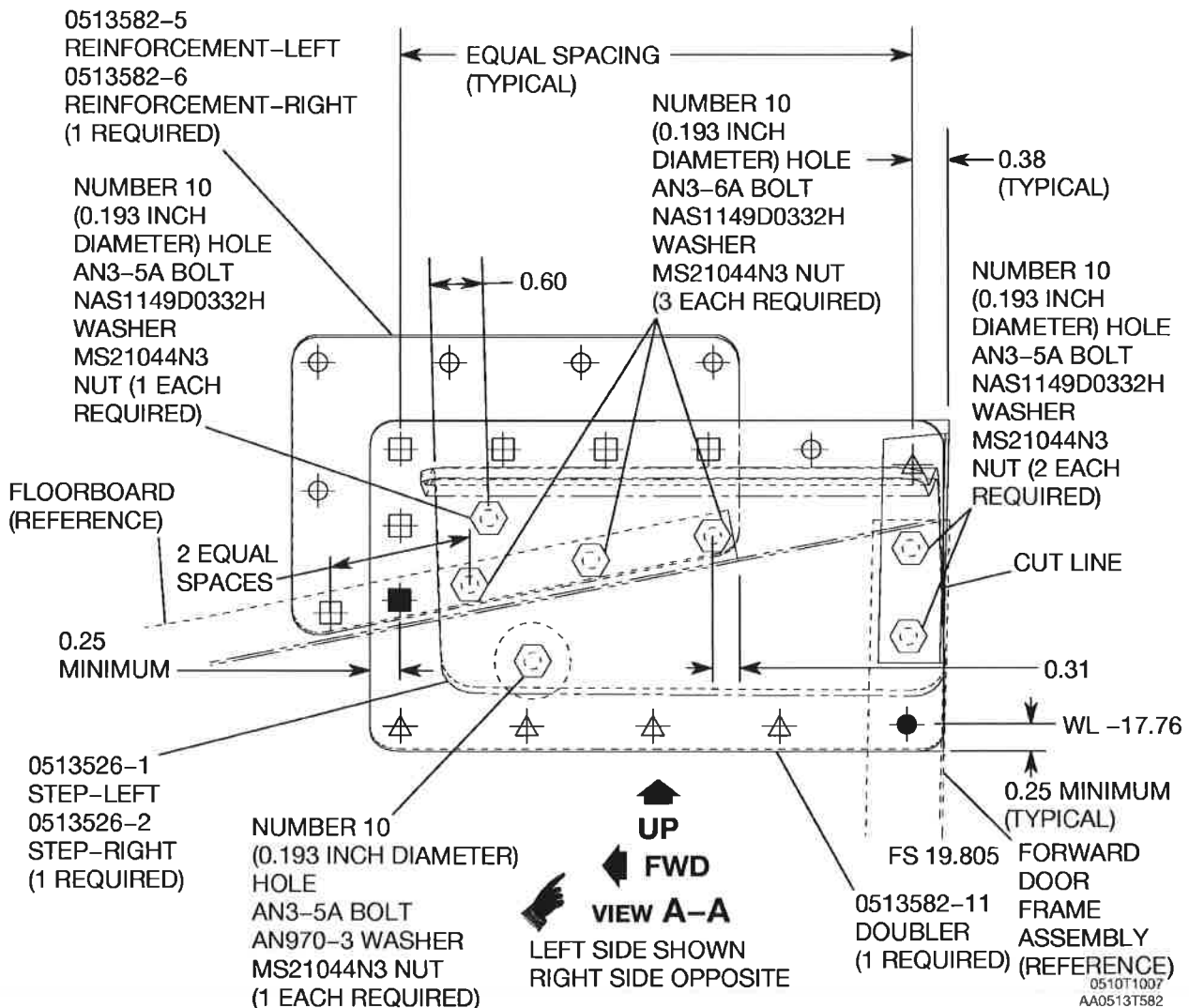
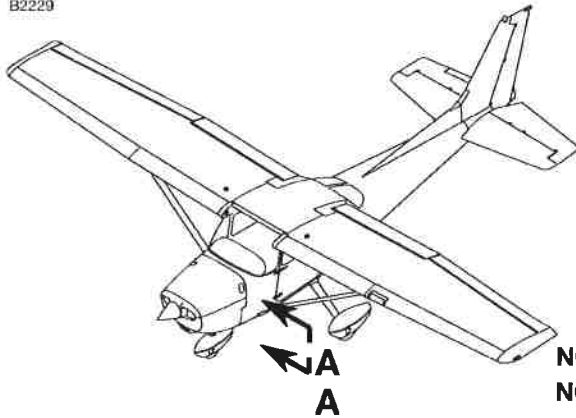

Figure 3. 0513526 Fuel Step Installation (Sheet 1)

ACCESSORY KIT

AK172-168J

B2229



RIVET LEGEND	
	MS20470AD4-4.5
	MS20470AD4-5.5 (NOTE 2)
	MS20470AD4-6
	S2906-4-2
	MS20470AD5-7

NOTE 1: ALL DIMENSIONS SHOWN ARE IN INCHES.

NOTE 2: USE MS20426AD4-5 INSTEAD OF MS20470AD4-5 IF REQUIRED FOR CLEARANCE.

NUMBER 10 (0.193 INCH DIAMETER) HOLE
AN3-5A BOLT
NAS1149D0332 WASHER
MS21044N3 NUT
(1 EACH REQUIRED)

0513582-5 REINFORCEMENT-LEFT
0513582-6 REINFORCEMENT-RIGHT
(1 REQUIRED)

NUMBER 10 (0.193 INCH DIAMETER) HOLE
AN3-6A BOLT
NAS1149D0332H WASHER
MS21044N3 NUT
(3 EACH REQUIRED)

NUMBER 10 (0.193 INCH DIAMETER) HOLE
AN3-5A BOLT
NAS1149D0332H WASHER
MS21044N3 NUT
(2 EACH REQUIRED)

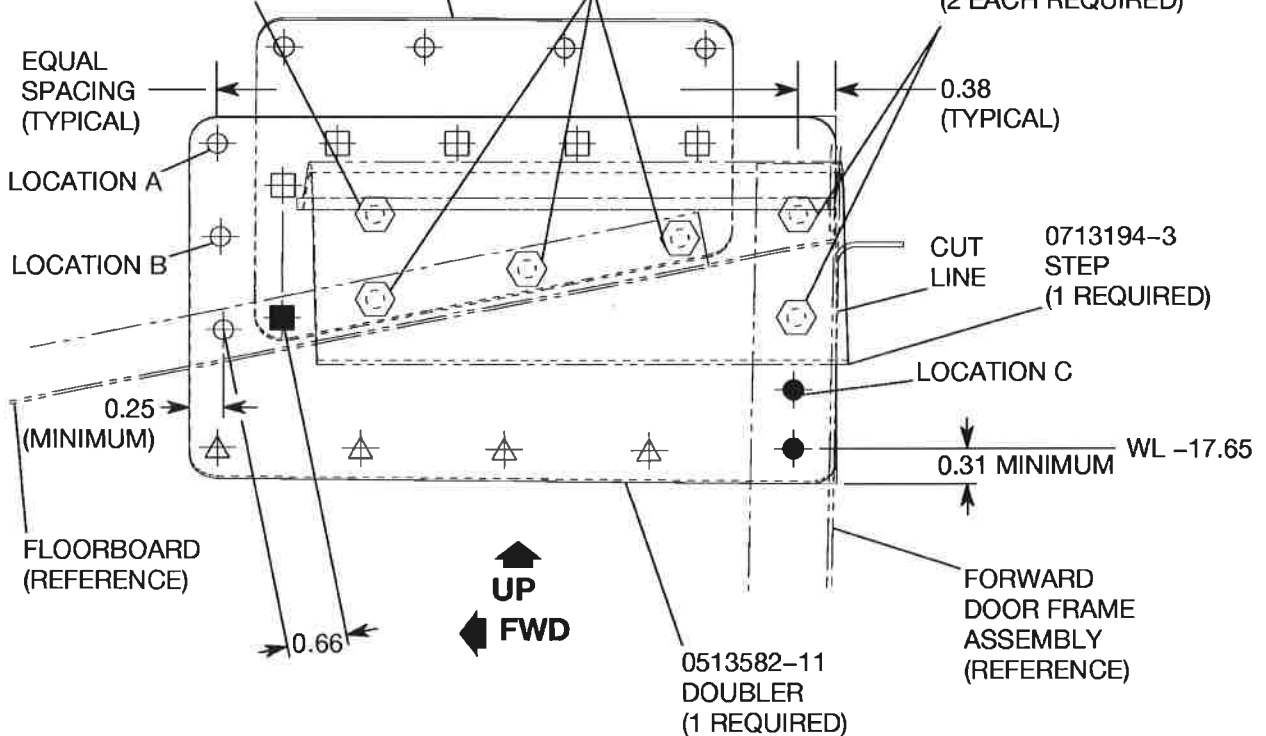

VIEW A-A



LEFT SIDE SHOWN
RIGHT SIDE OPPOSITE

AA0531T582

Figure 4. 0713194 Fuel Step Installation (Sheet 1)